

Strato

User Operated Brakes

INSTRUCTIONS FOR USE

Sizes 3, 4 & 5
Code: UOB001



CONTENTS	PAGE
1.0 INTRODUCTION	1
2.0 ILLUSTRATION OF YOUR STRATO USER OPERATED BRAKE KIT	2
3.0 FOR YOUR SAFETY	3
4.0 HOW TO USE YOUR PRODUCT	4
5.0 CARE AND MAINTENANCE	5
6.0 GUARANTEE & SERVICE	6
7.0 CONTINUOUS IMPROVEMENT	6
8.0 WARRANTY & AFTERSALE	6

1.0 INTRODUCTION

Thank you for choosing the Smirthwaite Strato User Operated Brake kit.

This kit enables the Strato client to gain independent operation of brakes whilst seated. The system is simple to operate, and can be fitted to the left or right of the client, as required. The kit is supplied factory fitted, but can be adjusted in the field as required to ensure optimized performance at all times.

	<p>IMPORTANT!</p> <p>These instructions should be read by all therapists and carers using the equipment and should be retained for future reference. The Strato itself requires an assessment to establish the user's needs and should always be used under adult supervision.</p> <p>Any incorrect use of the product and failure to follow the instructions may put the user at risk or impede the function. If you have any queries using this product or wish for further copies, please do not hesitate to contact Customer Service department on T: +44 (0) 1626 835552.</p>
---	---

2.0 ILLUSTRATION OF YOUR STRATO USER OPERATED BRAKES KIT

- A. Lever knob
- B. Lever
- C. Lever box (can be positioned left or right on armrest to suit client needs)
- D. Adjustor
- E. E. Balance box

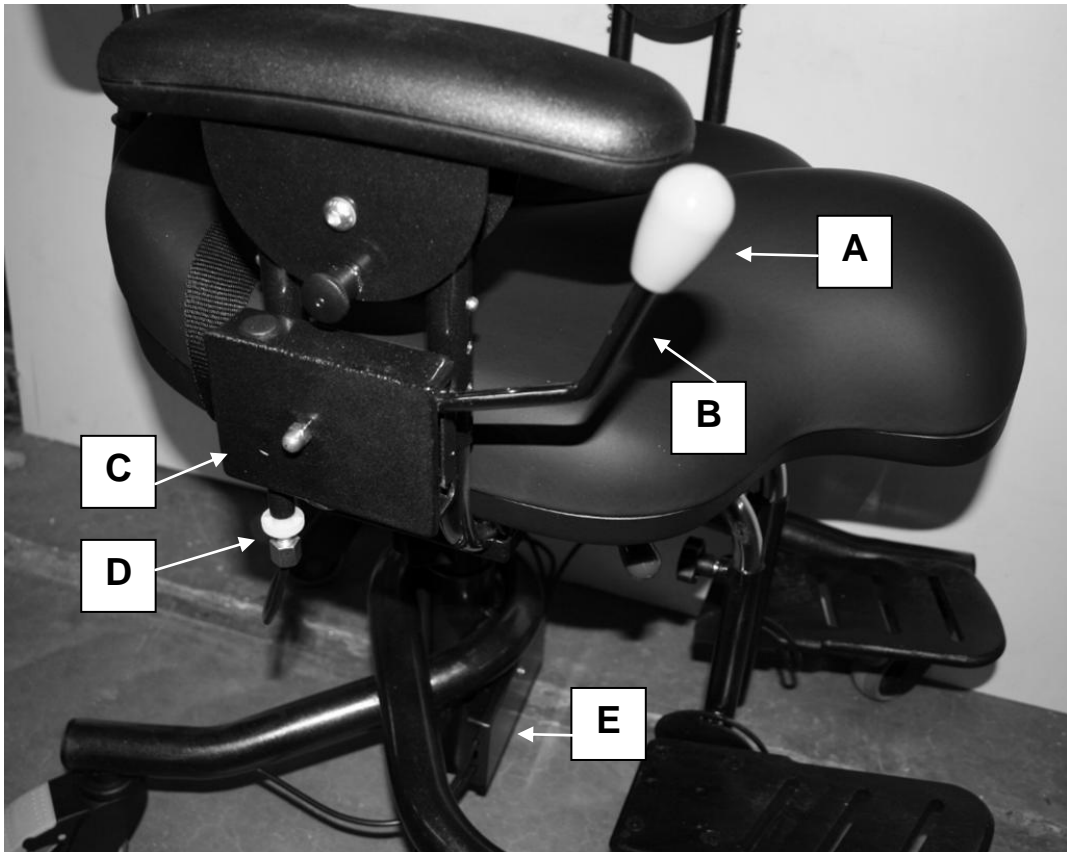

2.1 TECHNICAL DATA

Strato Size	1	2	3	4	5
Code	N/A	N/A	UOB001	UOB001	UOB001

3.0 FOR YOUR SAFETY

	STOP!
	Your STRATO chair comes complete with Instructions for Use (IFU) - please read these instructions CAREFULLY and THOROUGHLY. For your convenience, the main safety points are repeated below:

- The user should **NOT** be left unattended whilst in the chair. Always ensure a responsible therapist or carer is in attendance.
- The carer should be familiar with the methods of adjustment and have completed all adjustments appropriately to meet the needs of the child before transferring the child onto the chair.
- Regular maintenance checks and cleaning are essential for the safe use of this equipment (see care and maintenance section).
- Always fasten the pelvic strap and any other straps provided with the chair.
- Always lock at least two of the wheels when the chair is static.
- The castors of the Strato are designed for indoor use only, and may be damaged if used outdoors. The Strato should not be used as a transit chair.
- Regularly check that straps and/or harnesses are not showing signs of tearing or fraying, and that they fasten correctly.
- If any part is loose, damaged or functioning incorrectly, **DO NOT** use until rectified.
- Always keep this product away from naked flames, cigarettes and sources of heat including open fireplaces, radiators and heaters.
- **DO NOT** fit parts or accessories of other manufacturers to this product unless authorised to do so in writing by G&S Smirthwaite Ltd. Failure to follow these instructions will not only invalidate the guarantee but could make the chair dangerous to use. G&S Smirthwaite Ltd will not accept liability for any injury or damage incurred through such malpractices. Any repairs required must be carried out by G&S Smirthwaite Ltd authorised personnel.
- If you believe the chair or any fitted accessory to be faulty at any time, **DO NOT USE** – contact our Customer Services department on +44 (0) 1626 835552.

4.0 HOW TO USE YOUR PRODUCT

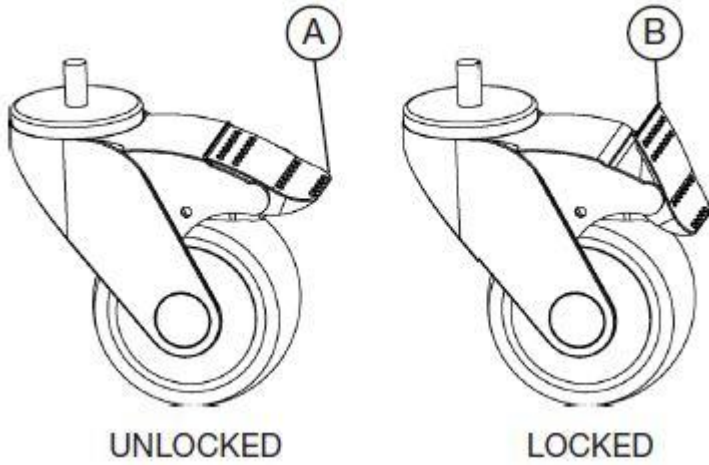
	IMPORTANT!
	Always lock the castors when attaching items or making adjustments. To lock, apply foot to point (A), to unlock apply foot to point (B). 

4.1 USER OPERATION

- To apply the brakes, simply push the lever (C) downwards.
- The brakes can then be locked on by parking the lever – simply pull the lever toward the seat cushion when it has reached its fully downward position.
- To release the brakes, push the lever (C) outward to release from its parked position.
- The lever is sprung loaded; once released it will automatically return to its top position.

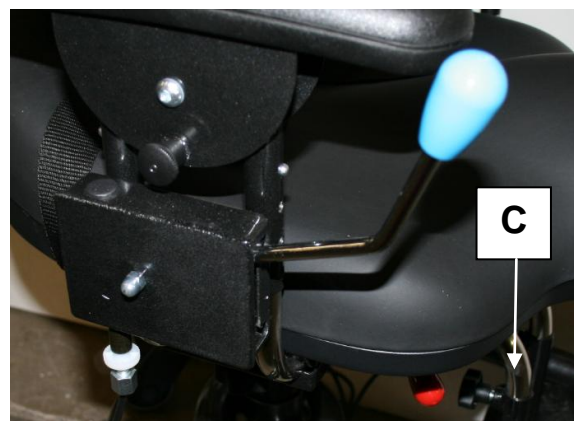

4.2 CARER OPERATION

- The product has been designed to permit any of the castors to be independently applied or released by a carer, using each individual castor foot pedal.
- See diagram above for castor brake information.
- If the user is having difficulty operating the brake system, check that none of the castors have had brakes applied directly.

5.0 CARE AND MAINTENANCE

	IMPORTANT!
	Cleaning is recommended on a regular basis – please refer to your STRATO IFU for full details.

5.1 DAILY CHECKS

- Check the braking system for damage or wear/tear.
- Operate the brake system, and check for sufficient hold and release.
- Check each castor independently, operating each individual castor brake.

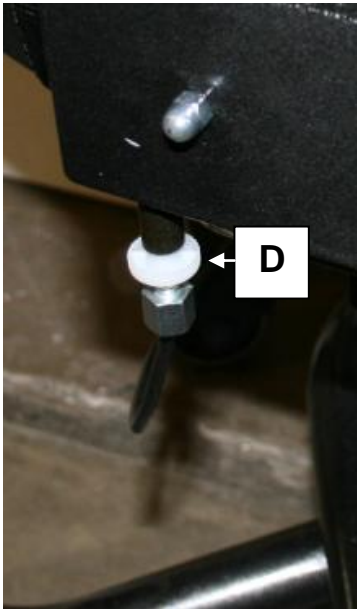
	STOP!
	<p>Over a prolonged period of use, it is likely the cable system will settle and require occasional adjustment.</p> <p>On the lever box there is an adjuster (D), which can be rotated to tighten the mechanism.</p> <p>Please contact the factory, or your local advisor, if you are in any doubt.</p> <div style="text-align: center;"></div>

5.2 SERVICE INTERVAL

The Strato Chair should be serviced every year. Servicing must only be undertaken by a Smirthwaite service engineer, or by a Smirthwaite trained representative.

6.0 GUARANTEE & SERVICE

The product is issued with a full parts and labour guarantee for 2 years from the date of delivery. This guarantee does not apply to accidental damage caused through inappropriate use of the product. This guarantee is issued at the discretion of G&S Smirthwaite Ltd on RTB (Return to Base) basis.

If you have any questions or doubts relating to the safety or use of the chair please contact us for advice or assistance on:

T: +44 (0) 1626 835552

E: info@smirthwaite.co.uk

7.0 CONTINUOUS IMPROVEMENT

G&S Smirthwaite Ltd are committed to continuous improvement to their product range. Should you have any suggestions or comments please send them to our product design department at: info@smirthwaite.co.uk.

G&S Smirthwaite Ltd reserve the right to change the specification or material without prior notice.

For catalogues, help and further information on our products please contact us at:

G&S Smirthwaite Ltd
17 Wentworth Road
Heathfield
Devon TQ12 6TL

T: +44 (0) 1626 835552

F: +44 (0) 1626 835428

E: info@smirthwaite.co.uk

W: www.smirthwaite.co.uk

8.0 WARRANTY & AFTERSALE

8.1 Product Information

Model:	
Size:	
Date of Manufacture:	
Serial Number:	

8.2 Service & inspection record form:

Date	Procedure	Service Personnel



G&S Smirthwaite, 17 Wentworth Road, Heathfield, Newton Abbot, Devon.TQ12 6TL
T: +44 (0) 1626 835552 F: +44 (0) 1626 835428 E: info@smirthwaite.co.uk
W: www.smirthwaite.co.uk